

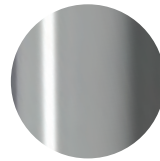

Australian designed and manufactured **Autoflo Integrated Goose-Neck Sensor Tap** is suitable for a range of hand-washing applications, particularly in public commercial areas that experience high traffic and therefore high usage, meaning conservation of water is of paramount importance. The 6-star WELS rating ensures hygienic bathroom environments for users, delivered economically and in an environmentally sensitive fashion.

The robust construction, sleek design is complemented by a range of features ensuring consistent performance. The ability to self-range to its environment, the hygienic self-flush performed every 24-72 hours are just some of what sets the **Autoflo Integrated Sensor Tap** apart from other visually similar taps on the market.

## CHROME



Mains 100-5156  
Battery 100-5162

## BRUSHED NICKEL

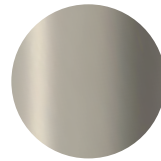

Mains 100-5157  
Battery 100-5163

## FEATURES

- Pre-programmed adjustable range
- Operation 240V mains or 6V battery
- Long battery life of 3-4 years
- Self-flushing every 24-72 hours
- Simple installation
- Dual stage water filter
- Suitable for high end applications

## SPECIFICATIONS

- TAP BODY - Solid brass, plated
- SENSOR OPERATION - IR Sensor
- SENSOR RANGE - 140mm factory set
- OPERATING SUPPLY - Mains or Battery
- OPERATING PRESSURE - 150 to 500kPa
- FLOW RATING - 4.5 L/min WELS 6 Star
- SOLENOID - Latching / soft-closing
- MAX TEMPERATURE - 50°C
- Suitable for tempered water

## DIMENSIONS

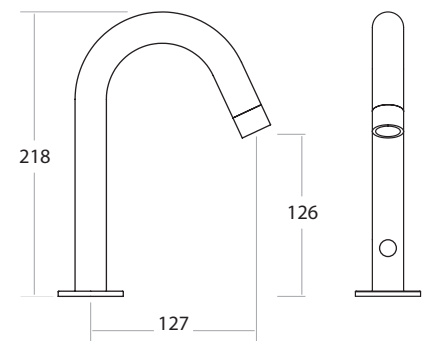

Every effort is made to ensure specifications are correct at the time of printing. Autoflo Pty Ltd reserves the right to make changes without prior notice. All measurements shown are in millimetres.