

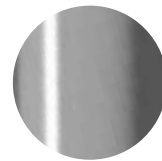

The Australian designed and manufactured **Autoflo Integrated Goose-neck Wave On/Wave Off** Sensor Tap Lead Free is suitable for a range of hand-washing applications, particularly in public commercial areas that experience high traffic and therefore high usage, meaning conservation of water is of paramount importance. The 6-star WELS rating ensures hygienic bathroom environments for users, delivered economically and in an environmentally sensitive fashion.

The robust construction and sleek design are complimented by a range of features ensuring consistent performance. The hygienic self flush performed every 24-72 hours and dual stage water filtering are just some of the features that set apart the **Autoflo Integrated Wave On/Wave Off** Sensor Tap.

CHROME



Mains 100-5160LF
Battery 100-5161LF

BRUSHED NICKEL

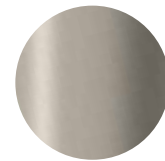

Mains 100-5158LF
Battery 100-5159LF

FEATURES

- Simple wave-on activation
- Pre-set hands free run time of 10 seconds
- Long battery life of 3-4 years
- Self flushing every 24-72 hours
- Simple installation
- Dual stage water filter
- Suitable for high end applications

SPECIFICATIONS

- TAP BODY - Solid brass plated
- SENSOR OPERATION - IR Sensor
- OPERATING SUPPLY - 240V Mains or 6V Battery
- OPERATING PRESSURE - 150 to 500kPa
- FLOW RATING - 4.5 litres per minute, WELS 6 Star
- SOLENOID - Latching / Soft-closing
- MAX TEMPERATURE - 50°C
- Suitable for tempered water

DIMENSIONS

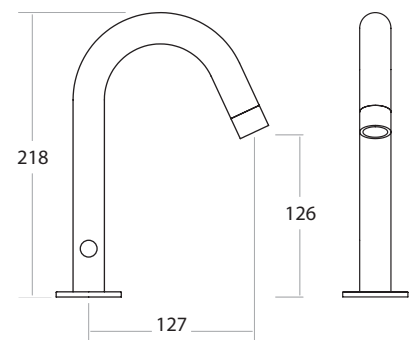

Every effort is made to ensure specifications are correct at the time of printing. Autoflo Pty Ltd reserves the right to make changes without prior notice. All measurements are shown in millimetres.